



The Ultimate Sealing Gasket



ADVANCE PRODUCTS & SYSTEMS

Integra SSA[®]
Cathodic Isolation Gaskets

Patent Pending

ISO-9001 Certified Company - FM537405



INTEGRA SSA® CATHODIC ISOLATION GASKETS

The Integra SSA® Cathodic Isolation Gasket is manufactured from proprietary G-FORCE 2000®, a special glass epoxy material with an impressively high compression strength; these materials are proprietary materials produced only for Advance Products & Systems.

This APS-exclusive gasket has an excellent mechanical strength as well as dynamic electrical isolating properties allowing it to perform efficiently and effectively in severe service applications under extreme pressures and elevated temperatures. Integra SSA® gaskets provide an outstanding sealing capability while installed in extremely high pressure applications; it can be installed in flanges from ANSI 150# to ANSI 2500# up to an API 10,000# flange. Integra SSA® gaskets have excellent electrical properties while at elevated temperatures. During mechanical operations, Integra SSA® gaskets can operate at 374°F.

Inserted in the gasket is a glass-reinforced, spring energized PTFE seal to assist in maintaining a high pressure, chemically resistant seal within the flange. Incorporated within the PTFE seal, a 316 stainless steel coil spring provides additional compression with minimal cold flow. These characteristics allow constant pressure to be applied, with low cold flow characteristics ultimately providing an outstanding seal and cathodically isolating the flange for superior reliability.

Integra SSA® gaskets are manufactured to accommodate RTJ, full and raised face flanges. All kit components include either G-10 or Mylar sleeves and G-10 isolating washers when Integra SSA® gaskets are installed.

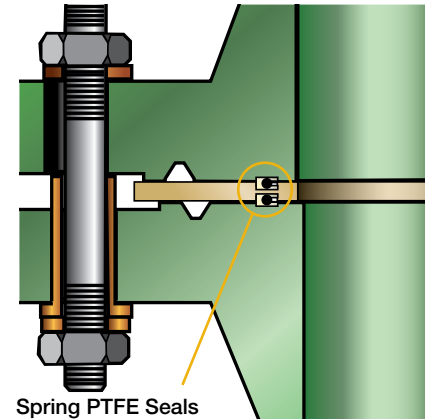
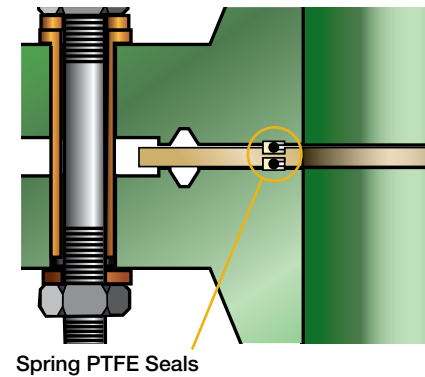
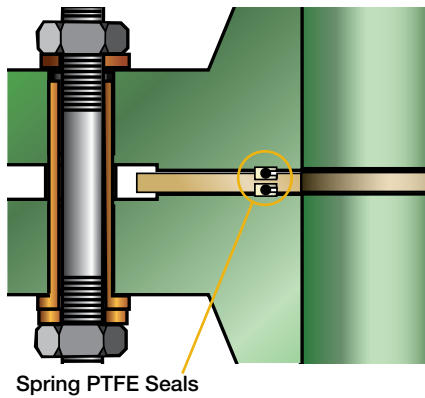
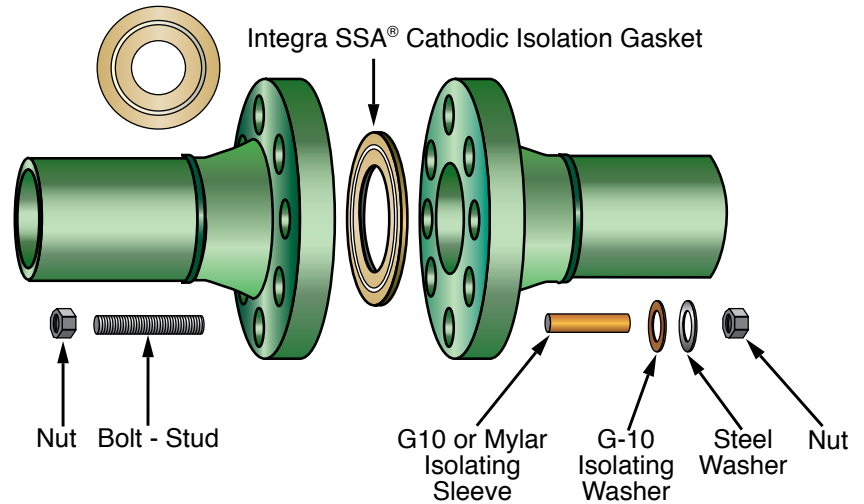

SEVERE SERVICE CATHODIC ISOLATION

When used with isolating sleeves and washers, the Integra SSA® is effective in eliminating electrical conductivity and also in preventing corrosion that results from contact between two dissimilar metals.

SPRING ENERGIZED PTFE SEALING CHARACTERISTICS

The strength and reliability of the Integra SSA® makes it a perfect replacement for a missing or faulty RTJ gasket.

VERSATILITY

Mismatched and misaligned flanges are easily sealed with the Integra SSA®.

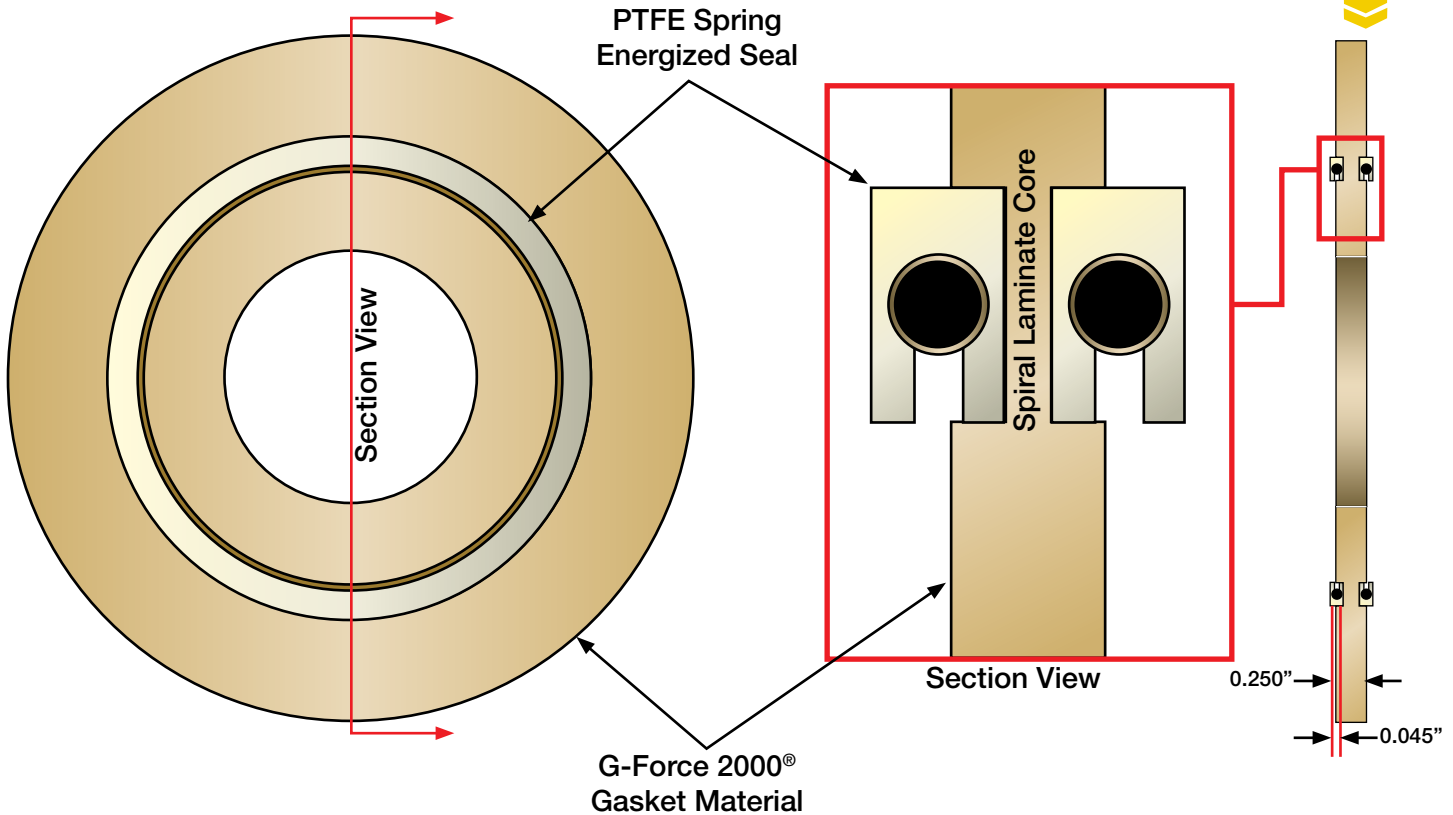

FEATURES & BENEFITS:

- Electrically isolates effectively for all pipeline and piping applications.
- Ensures a stringent seal in volatile applications.
- ANSI 150# up to API 10,000# ratings.
- The gasket is designed for severe pressure and temperature applications
- Composition is of proprietary G-Force 2000® material with a compressive strength of 91,000 PSI.
- Stainless Steel Spring-fortified PTFE seal uses a glass reinforced PTFE with low cold flow characteristics. Also available in Viton.
- These gaskets are constructed from an extremely high compressive strength material formulated for high temperatures. Integra SSA® gaskets are manufactured in 1/4 inch thick material.
- APS Integra SSA® gaskets have no metal core substrate material as part of its sealing and mechanical application.*

G-Force 2000® material is a flat epoxy laminate woven glass material. The continuous operating temperature is 374° F, 190° C in mechanical applications. This material meets NEMA Fiberglass and MIL-1-24768/3, Type GEB. Material Tested: 0.250 thickness.

TYPICAL PROPERTIES

General Physical Properties	Units	Value
Rockwell Hardness (.250)	M Scale	111
Moisture Absorption (.250)	%	0.12
Flexural Strength	psi	80,000
Tensile Strength LW	psi	61,000
Compressive Strength flatwise (.250")	psi	91,000
Maximum Operating Temperature	°C °F	190 ^{1,2} 374°

TO ORDER PLEASE SPECIFY THE FOLLOWING

1. Flange Specification
(ANSI/ASME, API, MSS SP44, BSI or Din Standard)
2. Nominal Pipe Size, Pressure Rating and Bore Size
3. Operating Pressure, Temperature and Media
4. Isolating Sleeve Material
5. Isolating Washer Material
6. Metal Washer Material (SS/Zinc Steel)

OTHER PRODUCTS AVAILABLE

- Standard Isolating Gasket Kits
- Kleerband® Flange Protectors
- Radolid® Nut & Bolt Protector Caps
- Casing Spacers and End Seals
- Innerlynx® Modular Mechanical Seals
- Monolithic Isolators
- Foreman Night Caps - temporary pipe plugs
- U-Bolt Cote®



ADVANCE PRODUCTS & SYSTEMS, INC.

PO Box 60399 • Lafayette, Louisiana 70596-0399
800-315-6009 • 337-233-6116 • FAX 337-232-3860
E-Mail: sales@apsonline.com • Website: www.apsonline.com

Distributed by:

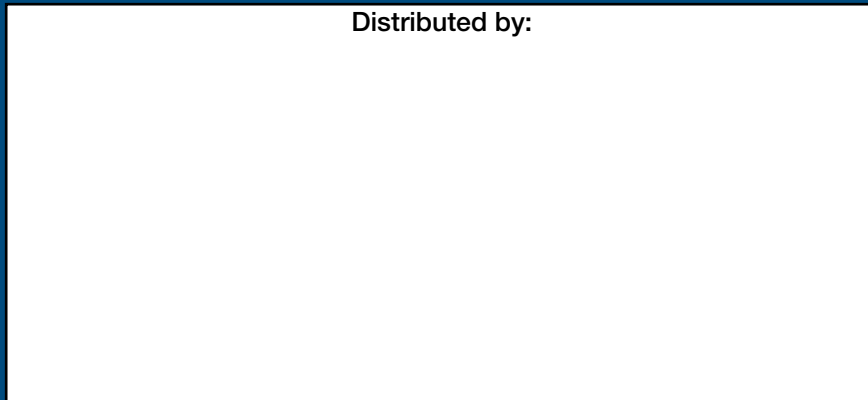

Made in USA

Advance Products & Systems, Inc. is not responsible for errors printed in this brochure.

Advance Products & Systems, Inc. shall repair or replace (within the limitations of such applicable express written warranty as may be issued by it) any product or portions thereof, which prove to be defective in workmanship or material for a period of 12 months from shipment date. The foregoing in lieu of all warranties, express or implied, and all other obligations or liabilities on the part of APS, on account of the product which it may sell. In no event shall APS be liable for consequential or special damages: nor except as it may otherwise specifically agree in writing, installation, or other work which may be done upon or in connection with the product by APS/ the distribution / dealer or others. THE LIMITED WARRANTIES PROVIDED IN THIS AGREEMENT AND THE OBLIGATIONS AND LIABILITIES OF APS ARE THE ONLY WARRANTIES MADE BY APS AS TO THE PRODUCT. APS MAKES NO EXPRESS OR OTHER IMPLIED WARRANTIES, BY COURSE OF DEALING, USAGE OF TRADE, MERCHANTABILITY, FITNESS FOR A PARTICULAR USE (WHETHER GENERAL OR SPECIFIC), OR OTHERWISE.