



UBolt-Cote[®]
and Atlas[®] Pipe Support





UBOLT-COTE® & ATLAS PIPE SUPPORT® PADS

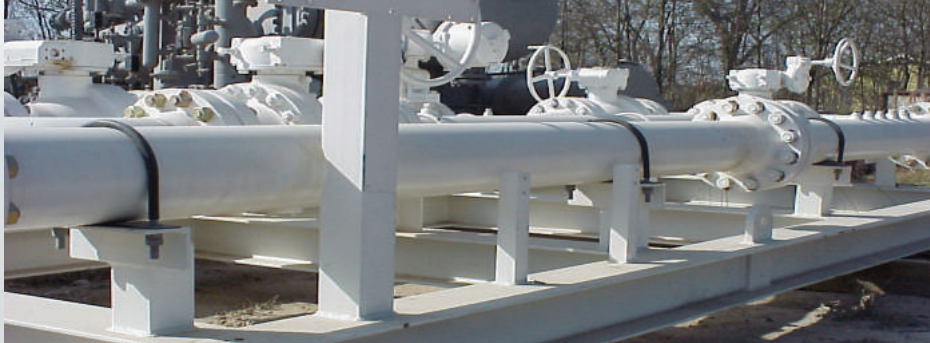

PREVENT CORROSION

This is a typical example of accelerated corrosion occurring due to metal contact between the uncoated ubolt and the pipe. The excessive corrosion and pitting can eventually develop into pinhole leaks. This interaction can be completely eliminated by utilizing APS UBolt -Cote® in conjunction with Atlas® Pipe Supports.



APPLICATION

UBolt-Cote® is excellent for eliminating corrosion problems on piping in refineries, chemical plants, paper mills, offshore platforms, rigs and the shipping industry. It is also excellent for shock absorption on plastic, FRP or glass-lined pipe and will help to reduce vibration and noise levels.

ADVANTAGES

Versatility - with a wide variety of sizes available, UBolt-Cote® can be applied to all sizes of ubolts.

Protection - A rugged and durable covering, eliminating metal to metal contact.

Reliability - Virtually unaffected by heat, ultraviolet rays, vibration, electrolysis, sandblasting or other rigors conducive to an industrial and marine environment.

Ease of Installation - The ubolt size has been considered to accommodate the coating thickness assuring a good fit over the pipe.

FEATURES

UBolt-Cote® is a seamless, vulcanized, polyolefin material that can be applied to all types of ubolts. It is available on hot-dipped galvanized, Xylan (PTFE), carbon steel, and on stainless steel.

ATLAS PIPE SUPPORT® PADS



"Strong Enough to Hold the World, Built to Hold Your Pipe"

The Atlas 180® and Atlas 360® pipe support pads are the best pipe support solution due to zero water absorption and with minimal contact between pad and pipe, the possibility of crevice corrosion is eliminated. Also, Atlas® pads contain a UV additive to resist the harmful, degrading effects of sunlight.

Note: Black pads provide better UV resistance than white pads. Both are made of high-density thermoplastic material.



Atlas 180®

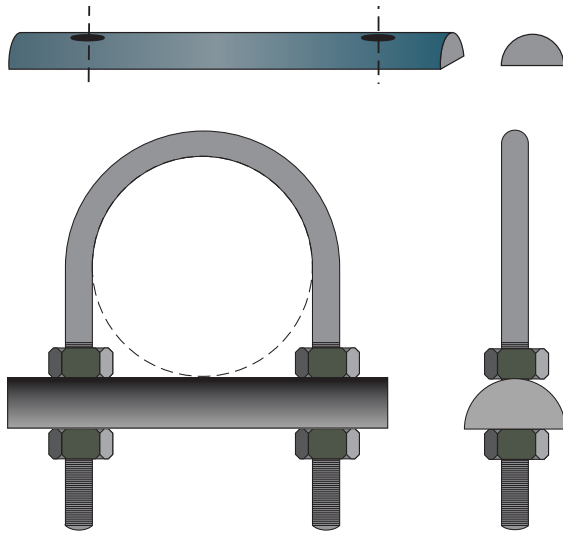

Atlas 360®

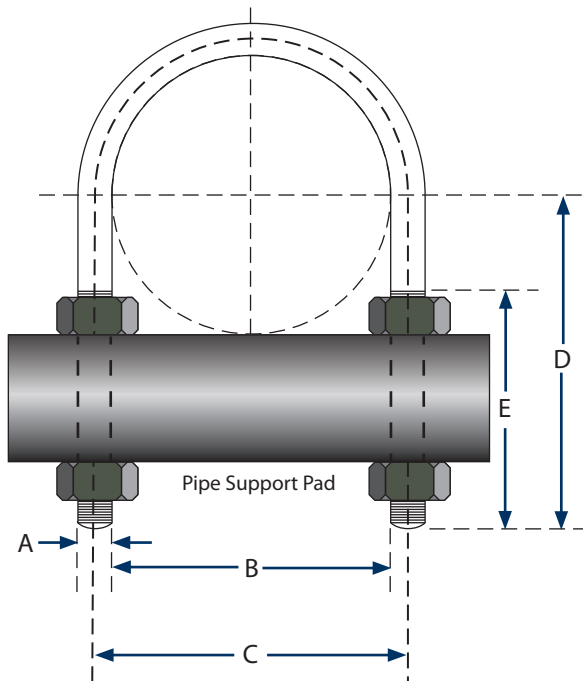
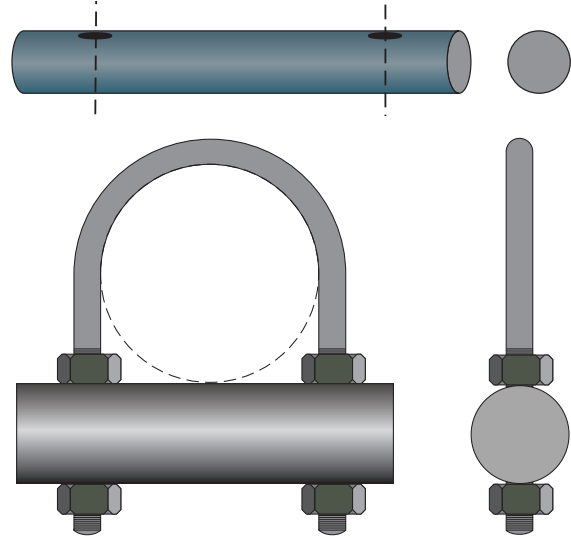

Dimensional Data

Pipe Size	A	B	C	D	E	Weight per 100
1/2	1/4	15/16	1-3/16	2-3/4	2-3/8	11
3/4	1/4	1-1/8	1-3/8	2-3/4	2-3/8	13
1	1/4	1-3/8	1-5/8	2-3/4	2-3/8	14
1-1/4	3/8	1-11/16	2-1/16	2-7/8	2-1/2	38
1-1/2	3/8	2	2-3/8	3	2-1/2	39
2	3/8	2-7/16	2-13/16	3-1/8	2-1/2	42
2-1/2	1/2	2-15/16	3-7/16	3-3/4	3	90
3	1/2	3-9/16	4-1/16	4	3	99
3-1/2	1/2	4-1/16	4-9/16	4-1/4	3	105
4	1/2	4-9/16	5-1/16	4-1/2	3	115
5	1/2	5-5/8	6-1/8	5	3	128
6	5/8	6-3/4	7-3/8	5-1/8	3-3/4	239
8	5/8	8-3/4	9-3/8	7-1/8	3-3/4	283
10	3/4	10-7/8	11-5/8	8-3/8	4	479
12	7/8	12-7/8	13-3/4	9-5/8	4-1/4	764
14	7/8	14-1/8	15	10-1/4	4-1/4	820
16	7/8	16-1/8	17	11-1/4	4-1/4	870
18	1	18-1/8	19-1/8	12-5/8	4-3/4	1350
20	1	20-1/8	21-1/8	13-5/8	4-3/4	1460
24	1	24-1/8	25-1/8	15-5/8	4-3/4	1710
28	1	28-1/8	29-1/8	17-5/8	4-3/4	1800
30	1	30-1/8	31-1/8	18-5/8	4-3/4	1910
36	1	36-1/8	37-1/8	21-5/8	4-3/4	2320

Galvanized long tangent ubolts ranging in sizes from 3/4" through 20" are stock items. Larger sizes available upon request. All assemblies include coated ubolts, 4 nuts and pad.



Physical Properties		
Tensile Strength	1500 psi min.	ASTM D412
Elongation	300% min	ASTM D412
Heat Aging (168 hrs/121 °C)	1500 psi min	ASTM D2671
Tensile Elongation	300% min	ASTM D2671
Heat Shock	No cracks, flow or blisters	ASTM D2671
Low Temp. Flexibility (4hrs/-55 °C)	No cracking	ASTM D2671
Specific Gravity/ Temperature Limitation	0.96/200%	ASTM D792
Chemical Properties		
Water Absorption	0.2%	ASTM D570
Corrosive Effect (16hrs/175 °C)	Pass	ASTM D2671 /Copper Rod
Fluid Resistance (24hrs/25 °C)		
Hydraulic Fluid (MIL-H-5606C)		
Tensile	90% retained min	ASTM D412
Elongation	90% retained min	ASTM D412
Lubricating Oil (MIL-L-7808G)		
Tensile	90% retained min	ASTM D412
Elongation	90% retained min	ASTM D412
Diesel Fuel (MIL-L-23699)		
Tensile	90% retained min	ASTM D412
Elongation	90% retained min	ASTM D412

OPTIONAL POWDER COATED UBOLT

General Description

This product has a high flow, functionalized polyethylene copolymer-based thermoplastic powder coating designed for maximum mechanical performance, impact resistance and UV-stability.

Application Data

- Recommended thickness is a minimum of 50 mils, and a maximum of 70 mils.
- Our proprietary material, Gal-vo-plast®, is also used as a powder coat on ubolts. The melting point of Gal-vo-plast® is 221 °F.

Performance Properties	Testing Method	Results
Adhesion	ASTM D 4541, ASTM D 3359	>800 PSI (test conducted on blasted substrate)
Hardness (Shore D)	ASTM D 2240	52
Impact Resistance	ASTM B 2794	>384 in./lbs.
Salt Spray Resistance	ASTM b-117	>2,000 hours
Humidity Resistance	ASTM D 2247	No blistering or loss of gloss after 1,000 hours
Taber Abrasion	ASTM D 4060	100 (mg loss, CS 17 wheel)
Mandrel Bend	ASTM D 522	1/8 inch, no cracks (>32%)
Melt Index	ASTM D 1238	207
Gloss	ASTM D 523	60 - 75



EXTREME TEMPERATURE UBOLT-COTE® & ATLAS PIPE SUPPORT® PADS

UBOLT-COTE®

Extreme temperature UBolt-Cote are available in HT and XT materials. Both materials offer excellent chemical resistance, low coefficient of friction, and excellent UV resistance.

Properties	HT UBolt -Cote® Results	XT UBolt-Cote® Results
Continuous Operating Temperature	Max 302° F (150° C or 175° C)	-454° F to 500° F (-270° C to 260° C)

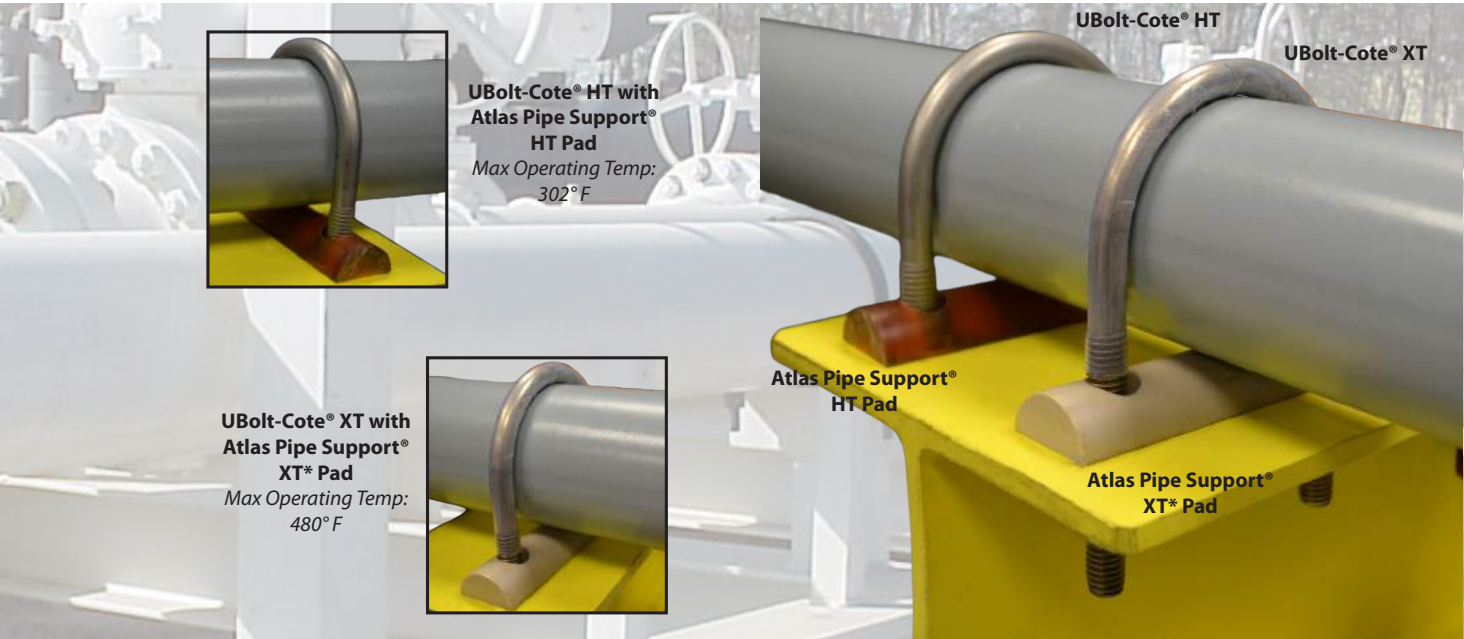

ATLAS PIPE SUPPORT® PADS

Extreme temperature pads are available in Atlas Pipe Support® HT and Atlas Pipe Support® XT* materials. Both materials offer excellent chemical resistance, low moisture absorption, and are not affected by continuous exposure to hot water and steam environments. Atlas Pipe Support® HT pads offer excellent chemical resistance.

Properties	Atlas Pipe Support® HT Results (Amber)	Atlas Pipe Support® XT* Results (Beige)	Testing Method
Density	0.0462 lb/in ³	0.047 lb/in ³	D792
Water Absorption, 24 hours	0.25%	0.10	D570
Tensile Strength	16,500 psi	16,000 psi	D638
Tensile Modulus	500,000 psi	500,000 psi	D638
Tensile Elongation at Break	80%	20%	D638
Flexural Strength	20,000 psi	25,000 psi	D790
Flexural Modulus	500,000 psi	600,000 psi	D790
Compressive Strength	22,000 psi	20,000 psi	D695
Compressive Modulus	480,000 psi	500,000 psi	D695
Coefficient of Friction	0.42	0.40	N/A QTM 55007
Hardness, Rockwell, M/R	112/125	100/126	D785
IZOD Notched Impact	0.5 ft-lb/in	1.0 ft-lb/in	D256
Coefficient of Linear Thermal Expansion	3.1	2.6	E831
Maximum Operating Temperature	340° F (171° C)	480° F (249° C)	
Melting Point	410° F (210° C)	644° F (340° C)	D3418
Heat Deflection Temperature at 264 psi	400° F (204° C)	320° F (160° C)	D648
Flammability Rating	V-0	V-0	UL94
Dielectric Strength, short-term	830 V/mil	480 V/mil	D149

TO ORDER PLEASE SPECIFY THE FOLLOWING

1. Pipe Size
2. Material: Carbon steel or stainless steel
3. Coating: Galvanized or Xylan (PTFE)
4. Pad: Buna-N, viton or thermoplastic

OTHER PRODUCTS AVAILABLE

- Kleerband[®] Flange Band Protectors
- Radolid[®] Bolt & Nut Protection Caps
- Casing Spacers and End Seals
- Innerlynx[®] - Modular Mechanical Seals
- IsoJoint[®] - Monolithic Isolators
- Foreman Nite Caps - Temporary Pipe Plugs
- Standard Isolating Gasket Kits
- Integra SSA[®] - Cathodic Isolating Gasket Kits



ADVANCE

PRODUCTS & SYSTEMS, LLC

P. O. Box 60399 • Lafayette, Louisiana 70596-0399
800-315-6009 • 337-233-6116 • FAX: 337-232-3860
Email: sales@apsonline.com • Website: www.apsonline.com



Distributed by:

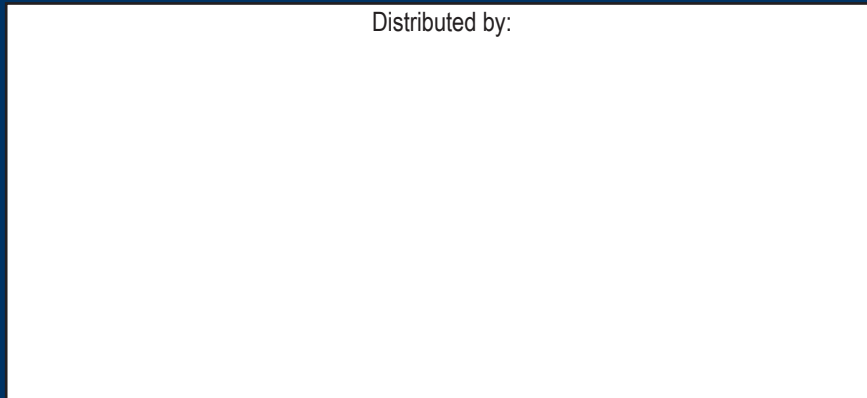

Advance Products & Systems, LLC is not responsible for errors printed in this brochure.

Advance Products & Systems, LLC shall repair or replace (within the limitations of such applicable express written warranty as may be issued by it) any product or portions thereof, which prove to be defective in workmanship or material for a period of 12 months from shipment date. The foregoing in lieu of all warranties, express or implied, and all other obligations or liabilities on the part of APS, on account of the product which it may sell. In no event shall APS be liable for consequential or special damages: nor except as it may otherwise specifically agree in writing, installation, or other work which may be done upon or in connection with the product by APS/ the distribution / dealer or others. THE LIMITED WARRANTIES PROVIDED IN THIS AGREEMENT AND THE OBLIGATIONS AND LIABILITIES OF APS ARE THE ONLY WARRANTIES MADE BY APS AS TO THE PRODUCT. APS MAKES NO EXPRESS OR OTHER IMPLIED WARRANTIES, BY COURSE OF DEALING, USAGE OF TRADE, MERCHANTABILITY, FITNESS FOR A PARTICULAR USE (WHETHER GENERAL OR SPECIFIC), OR OTHERWISE.